

FOR MAXIMUM PRODUCTIVITY

Automated sheet roll change without interrupting production –
with integrated lift-in system

LIFT

Continuous production

Smart foil roll changer

With the GABLER LIFT, production interruptions due to foil roll changes are a thing of the past. With it, the change can be carried out quite simply during the ongoing production process. This minimizes downtimes, lowers material costs and reduces personnel expenses. The LIFT can be operated with any thermoforming system and thus offers extremely high flexibility.



LIFT

The electrically operated lifting unit with a chain drive allows even larger sheet rolls with diameters of up to 2,200 mm and weighing up to 2,000 kg. The double roll Movimot drive and dancer controller allow the payoff speed to be optimally

adapted to the thermoforming machine – for smooth and jerk-free unwinding of the sheet roll. Welding the two sheet ends together is quick and easy with the optional ultrasonic sealing gun on the integrated cutting table.

Technical overview of the LIFT:

- 1 Sheet roll
- 2 Lifting unit
- 3 Remainder of the sheet roll
- 4 Cutting table
- 5 Dual-roll outlet drive motor
- 6 Dancer controller

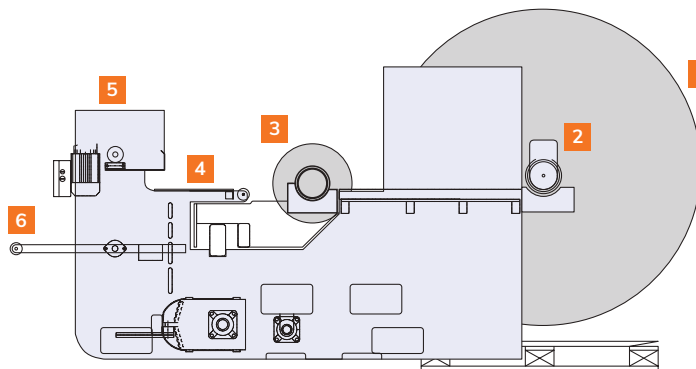

**RELIABLE
PARTNER**

A financially sound company, one of the world-market leaders in high end thermoforming technology – with branches all over the world



**COMPREHENSIVE
EXPERTISE**

Almost 50 years of experience in thermoforming



**EXPERT
SERVICE**

International network of experienced service technicians, rapid help on site, regular maintenance of your plants and fast, world-wide spare parts delivery



**STATE OF THE ART
TECHNOLOGY**

Innovations in the fields of pre-stretching technology, tool cooling, machine control, remote support, digitalization, and many more

GABLER Thermoform GmbH & Co KG
Niels-Bohr-Ring 5a
D 23568 Lübeck
Tel. +49 (0) 451 3109-0

GABLER
THERMOFORM TECHNOLOGY

 www.gabler-thermoform.com